

QUESTION PAPER CODE 65/1/1  
**EXPECTED ANSWER/VALUE POINTS**  
**SECTION A**

- |   | Marks                       |
|---|-----------------------------|
| 1. $\hat{a} = \frac{1}{\sqrt{5}}\hat{i} - \frac{2}{\sqrt{5}}\hat{j}$ then $7\hat{a} = \frac{7}{\sqrt{5}}\hat{i} - \frac{14}{\sqrt{5}}\hat{j}$ | $\frac{1}{2} + \frac{1}{2}$ |
| 2. $(\sqrt{2}\vec{a} - \vec{b}) \cdot (\sqrt{2}\vec{a} - \vec{b}) = 1 \Rightarrow \theta = \frac{\pi}{4}$                                     | $\frac{1}{2} + \frac{1}{2}$ |
| 3. $\cos^2 \alpha + \cos^2 \beta + \cos^2 \gamma = 1 \Rightarrow \sin^2 \alpha + \sin^2 \beta + \sin^2 \gamma = 2$                            | $\frac{1}{2} + \frac{1}{2}$ |
| 4. $AB = \begin{bmatrix} -1 & 5 \\ 4 & 8 \end{bmatrix} \Rightarrow  AB  = -28$  | $\frac{1}{2} + \frac{1}{2}$ |
| 5. $1 \cdot y + x \frac{dy}{dx} = -c \sin x \Rightarrow x \frac{dy}{dx} + y + xy \tan x = 0$  | $\frac{1}{2} + \frac{1}{2}$ |
| 6. order = 2, degree = 3, sum = 2 + 3 = 5   | $\frac{1}{2} + \frac{1}{2}$ |

**SECTION B**

7. System of equation is
- $$3x + y + 2z = 1100, x + 2y + 3z = 1400, x + y + z = 600$$
- $1\frac{1}{2}$
- (i) Matrix equation is
- $$\begin{bmatrix} 3 & 1 & 2 \\ 1 & 2 & 3 \\ 1 & 1 & 1 \end{bmatrix} \begin{bmatrix} x \\ y \\ z \end{bmatrix} = \begin{bmatrix} 1100 \\ 1400 \\ 600 \end{bmatrix}$$
- 1
- (ii)  $|A| = -3 \neq 0$ , system of equations can be solved.  $\frac{1}{2}$
- (iii) Any one value with reason. 1

$$8. [2x \quad 3] \begin{bmatrix} 1 & 2 \\ -3 & 0 \end{bmatrix} \begin{bmatrix} x \\ 3 \end{bmatrix} = 0$$

$$[2x-9 \quad 4x] \begin{bmatrix} x \\ 3 \end{bmatrix} = 0$$

1

$$[2x^2 - 9x + 12x] = [0] \Rightarrow 2x^2 + 3x = 0, x = 0 \text{ or } \frac{-3}{2}$$

1+1+1

$$9. \begin{vmatrix} (a+1)(a+2) & a+2 & 1 \\ (a+2)(a+3) & a+3 & 1 \\ (a+3)(a+4) & a+4 & 1 \end{vmatrix}$$

$$= \begin{vmatrix} (a+1)(a+2) & a+2 & 1 \\ 2(a+2) & 1 & 0 \\ 4a+10 & 2 & 0 \end{vmatrix} \left. \begin{array}{l} R_2 \rightarrow R_2 - R_1 \\ R_3 \rightarrow R_3 - R_1 \end{array} \right\}$$

1+1

$$= 4a + 8 - 4a - 10 = -2.$$

1+1

$$10. I = \int_0^{\pi/2} \frac{1}{1 + \sqrt{\tan x}} dx$$

$$I = \int_0^{\pi/2} \frac{1}{1 + \sqrt{\tan(\pi/2 - x)}} dx = \int_0^{\pi/2} \frac{1}{1 + \sqrt{\cot x}} dx = \int_0^{\pi/2} \frac{\sqrt{\tan x}}{1 + \sqrt{\tan x}} dx$$

1½

$$\Rightarrow 2I = \int_0^{\pi/2} \frac{1 + \sqrt{\tan x}}{1 + \sqrt{\tan x}} dx = \int_0^{\pi/2} 1 \cdot dx = \frac{\pi}{2}$$

1½

$$\Rightarrow I = \frac{\pi}{4}$$

1

$$11. \frac{x}{(x-1)^2(x+2)} = \frac{A}{x-1} + \frac{B}{(x-1)^2} + \frac{C}{x+2}$$

½

$$A = \frac{2}{9}, B = \frac{1}{3}, C = -\frac{2}{9}$$

1½

$$\int \frac{x}{(x-1)^2(x+2)} dx = \int \frac{2}{9(x-1)} dx + \int \frac{1}{3(x-1)^2} dx - \int \frac{2}{9(x+2)} dx \quad 1\frac{1}{2}$$

$$= \frac{2}{9} \log|x-1| - \frac{1}{3(x-1)} - \frac{2}{9} \log|x+2| + C \quad 1\frac{1}{2}$$

12. Let X be the number of defective bulbs. Then

$$X = 0, 1, 2 \quad 1$$

$$P(X=0) = \frac{10C_2}{15C_2} = \frac{3}{7}, \quad P(X=1) = \frac{10C_1 \cdot 5C_1}{15C_2} = \frac{10}{21} \quad 1+1$$

$$P(X=2) = \frac{5C_2}{15C_2} = \frac{2}{21} \quad 1$$

X	0	1	2
P(X)	$\frac{3}{7}$	$\frac{10}{21}$	$\frac{2}{21}$

OR

$E_1$ : Problem is solved by A.

$E_2$ : Problem is solved by B.

$$P(E_1) = \frac{1}{2}, P(E_2) = \frac{1}{3}, P(\bar{E}_1) = \frac{1}{2}, P(\bar{E}_2) = \frac{2}{3} \quad 1$$

$$P(E_1 \cap E_2) = P(E_1) \cdot P(E_2) = \frac{1}{6}$$

$$P(\text{problem is solved}) = 1 - P(\bar{E}_1) \cdot P(\bar{E}_2) = 1 - \frac{1}{2} \cdot \frac{2}{3} = \frac{2}{3} \quad 1\frac{1}{2}$$

$$P(\text{one of them is solved}) = P(E_1)P(\bar{E}_2) + P(\bar{E}_1)P(E_2)$$

$$= \frac{1}{2} \cdot \frac{2}{3} + \frac{1}{2} \cdot \frac{1}{3} = \frac{1}{2} \quad 1\frac{1}{2}$$

$$13. \left. \begin{aligned} \overline{AB} &= -4\hat{i} - 6\hat{j} - 2\hat{k} \\ \overline{AC} &= -\hat{i} + (\lambda - 5)\hat{j} + 3\hat{k} \\ \overline{AD} &= -8\hat{i} - \hat{j} + 3\hat{k} \end{aligned} \right\} \quad 1\frac{1}{2}$$

$$\overline{AB} \cdot (\overline{AC} \times \overline{AD}) = \begin{vmatrix} -4 & -6 & -2 \\ -1 & \lambda - 5 & 3 \\ -8 & -1 & 3 \end{vmatrix} = 0 \quad 1$$

$$-4(3\lambda - 12) + 6(21) - 2(8\lambda - 39) = 0 \Rightarrow \lambda = 9 \quad 1\frac{1}{2}$$

$$14. \left. \begin{aligned} \vec{a}_1 &= \hat{i} + 2\hat{j} + \hat{k}, \vec{b}_1 = \hat{i} - \hat{j} + \hat{k} \\ \vec{a}_2 &= 2\hat{i} - \hat{j} - \hat{k}, \vec{b}_2 = 2\hat{i} + \hat{j} + 2\hat{k} \end{aligned} \right\} \quad 1$$

$$\vec{a}_2 - \vec{a}_1 = \hat{i} - 3\hat{j} - 2\hat{k}, \vec{b}_1 \times \vec{b}_2 = \begin{vmatrix} \hat{i} & \hat{j} & \hat{k} \\ 1 & -1 & 1 \\ 2 & 1 & 1 \end{vmatrix} = -3\hat{i} + 3\hat{k} \quad \frac{1}{2} + 1$$

$$|\vec{b}_1 \times \vec{b}_2| = 3\sqrt{2} \quad \frac{1}{2}$$

$$(\vec{a}_2 - \vec{a}_1) \cdot (\vec{b}_1 \times \vec{b}_2) = -3 - 6 = -9$$

$$\text{Shortest distance} = \frac{|-9|}{|3\sqrt{2}|} = \frac{3\sqrt{2}}{2} \quad 1$$

$$15. \tan^{-1} 2x + \tan^{-1} 3x = \frac{\pi}{4}$$

$$\tan^{-1} \left( \frac{5x}{1-6x^2} \right) = \frac{\pi}{4} \quad 1$$

$$\frac{5x}{1-6x^2} = 1 \quad 1$$

$$\Rightarrow 6x^2 + 5x - 1 = 0 \quad 1$$

$$\Rightarrow x = \frac{1}{6}, x = -1 \text{ (rejected)} \quad 1$$

OR

$$\sin^{-1} \frac{5}{13} = \tan^{-1} \frac{5}{12} \quad 1$$

$$\cos^{-1} \frac{3}{5} = \tan^{-1} \frac{4}{3} \quad 1$$

$$\text{R.H.S.} = \sin^{-1} \frac{5}{13} + \cos^{-1} \frac{3}{5} = \tan^{-1} \frac{5}{12} + \tan^{-1} \frac{4}{3}$$

$$= \tan \left( \frac{\frac{5}{12} + \frac{4}{3}}{1 - \frac{5}{12} \cdot \frac{4}{3}} \right) \quad 1$$

$$= \tan^{-1} \frac{63}{16} \quad 1$$

$$16. \quad y = \frac{x \cos^{-1} x}{\sqrt{1-x^2}} - \log \sqrt{1-x^2}$$

$$\frac{dy}{dx} = \frac{\sqrt{1-x^2} \cdot \left( 1 \cos^{-1} x - \frac{x}{\sqrt{1-x^2}} \right) - \frac{x \cos^{-1} x (-2x)}{2\sqrt{1-x^2}}}{1-x^2} + \frac{2x}{2(1-x^2)} \quad 1+1$$

$$= \frac{\sqrt{1-x^2} \cos^{-1} x - x + \frac{x^2 \cos^{-1} x}{1-x^2}}{1-x^2} + \frac{x}{1-x^2} \quad 1$$

$$= \frac{(1-x^2) \cos^{-1} x + x^2 \cos^{-1} x}{(1-x^2)^{3/2}} = \frac{\cos^{-1} x}{(1-x^2)^{3/2}} \quad 1$$

$$17. y = (\sin x)^x + \sin^{-1} \sqrt{x}$$

$$\Rightarrow y = e^{x \log \sin x} + \sin^{-1} \sqrt{x} \quad 1$$

$$\Rightarrow \frac{dy}{dx} = e^{x \log \sin x} [\log \sin x + x \cot x] + \frac{1}{2\sqrt{x} \sqrt{1-x}} \quad 1\frac{1}{2}$$

$$\Rightarrow \frac{dy}{dx} = (\sin x)^x (\log \sin x + x \cot x) + \frac{1}{2\sqrt{x} \sqrt{1-x}} \quad 1\frac{1}{2}$$

$$18. x = a \sec^3 \theta$$

$$\frac{dx}{d\theta} = 3a \sec^3 \theta \tan \theta \quad \frac{1}{2}$$

$$y = a \tan^3 \theta$$

$$\frac{dy}{d\theta} = 3a \tan^2 \theta \sec^2 \theta \quad \frac{1}{2}$$

$$\frac{dy}{dx} = \frac{3a \tan^2 \theta \sec^2 \theta}{3a \sec^3 \theta \tan \theta} = \sin \theta \quad 1$$

$$\frac{d^2y}{dx^2} = \cos \theta \cdot \frac{d\theta}{dx} = \frac{\cos \theta}{3a \sec^3 \theta \tan \theta} = \frac{\cos^4 \theta}{3a \tan \theta} \quad 1$$

$$\left. \frac{d^2y}{dx^2} \right]_{\theta = \frac{\pi}{4}} = \frac{1}{12a} \quad 1$$

$$19. \int \frac{e^x(x^2+1)}{(x+1)^2} dx$$

$$= \int e^x \left[ \frac{(x^2-1)+2}{(x+1)^2} \right] dx \quad 1$$

$$= \int e^x \left[ \frac{x-1}{x+1} + \frac{2}{(x+1)^2} \right] dx \quad 1$$

$$= \frac{x-1}{x+1} \cdot e^x - \int \frac{2}{(x+1)^2} e^x dx + \int \frac{2}{(x+1)^2} e^x dx \quad 1$$

$$= \frac{e^x(x-1)}{x+1} + C \quad 1$$

### SECTION C

20.  $(a, b) * (c, d) = (a + c, b + d) = (c + a, d + b) = (c, d) * (a, b) \therefore *$  is commutative 1½

$$[(a, b) * (c, d)] * (e, f) = (a + c, b + d) * (e, f)$$

$$= (a + c + e, b + d + f) = (a, b) * (c + e, d + f) \quad 1$$

$$= (a, b) * [(c, d) * (e, f)] \therefore *$$
 is associate 1½

Let  $(e, e')$  be the identity

$$(a, b) * (e, e') = (a, b) \Rightarrow (a + e, b + e') = (a, b) \Rightarrow e = 0, e' = 0$$

$$\Rightarrow \text{Identity element is } (0, 0) \quad 2$$

21.

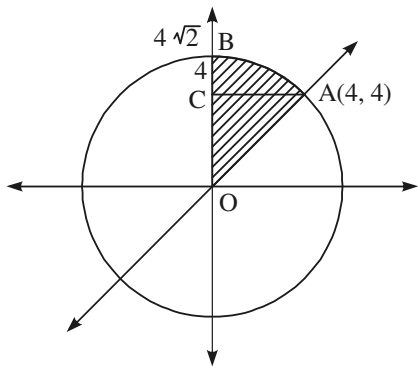

$$x^2 + y^2 = 32; y = x \text{ point of intersection is } y = 4 \quad ½$$

Correct figure 1

$$\text{Required Area} = \int_0^4 y dy + \int_4^{4\sqrt{2}} \sqrt{32 - y^2} dy \quad 1½$$

$$= \left[ \frac{y^2}{2} \right]_0^4 + \left[ \frac{y}{2} \sqrt{32 - y^2} + 16 \sin^{-1} \frac{y}{4\sqrt{2}} \right]_4^{4\sqrt{2}} \quad 1½$$

$$= 8 + \left( 0 + 16 \cdot \frac{\pi}{2} \right) - \left( 8 + 16 \cdot \frac{\pi}{2} \right) = 4\pi \quad 1½$$

22.  $x \frac{dy}{dx} + y - x + xy \cot x = 0 \Rightarrow \frac{dy}{dx} + \left( \frac{1}{x} + \cot x \right) y = 1 \quad ½$

$$\text{I.F.} = e^{\int \left( \frac{1}{x} + \cot x \right) dx} = x \sin x \quad 1$$

Solution:  $y \cdot x \sin x = \int 1 \cdot x \sin x \, dx$  1½

$\Rightarrow yx \sin x = -x \cos x + \sin x + C$  1

when

$x = \frac{\pi}{2}, y = 0$ , we have  $C = -1$  1

$yx \sin x + x \cos x - \sin x = 1$  1

OR

$x^2 dy + (xy + y^2) dx = 0 \Rightarrow \frac{dy}{dx} = \frac{-(xy + y^2)}{x^2}$  1

Put  $y = vx \Rightarrow \frac{dy}{dx} = v + x \frac{dv}{dx}$  1

$\Rightarrow v + x \frac{dv}{dx} = -(v + v^2) \Rightarrow \frac{dv}{v^2 + 2v} = -\frac{dx}{x}$

$\Rightarrow \int \frac{dv}{(v+1)^2 - (1)^2} - \int \frac{dx}{x} \Rightarrow \frac{1}{2} \log \frac{v}{v+2} = -\log x + \log C$  1

$\Rightarrow \frac{C}{x} = \sqrt{\frac{y}{y+x}}$  1

If  $x = 1, y = 1$ , then  $C = \frac{1}{\sqrt{3}}$  1

$\Rightarrow \frac{1}{\sqrt{3}x} = \sqrt{\frac{y}{y+x}}$  1

23. Plane passing through the intersection of given planes:

$(x + y + z - 1) + \lambda(2x + 3y + 4z - 5) = 0$  1

$(1 + 2\lambda)x + (1 + 3\lambda)y + (1 + 4\lambda)z + (-1 - 5\lambda) = 0$  1½

Now  $(1 + 2\lambda)1 + (1 + 3\lambda)(-1) + (1 + 4\lambda)1 = 0$  1½



$$\Rightarrow \lambda = -\frac{1}{3} \quad 1$$

Equation of required plane is

$$\Rightarrow x - z + 2 = 0 \quad 1$$

24.  $E_1$ : First bag is selected.   
 $E_2$ : Second bag is selected.   
A: both balls are red. } 1

$$P(E_1) = \frac{1}{2}, P(E_2) = \frac{1}{2}, P\left(\frac{A}{E_1}\right) = \frac{12}{56}, P\left(\frac{A}{E_2}\right) = \frac{2}{56} \quad \frac{1}{2} + \frac{1}{2} + 1 + 1$$

$$P\left(\frac{E_1}{A}\right) = \frac{P(E_1) P\left(\frac{A}{E_1}\right)}{P(E_1) P\left(\frac{A}{E_1}\right) + P(E_2) P\left(\frac{A}{E_2}\right)} = \frac{\frac{1}{2} \times \frac{12}{56}}{\frac{1}{2} \times \frac{12}{56} + \frac{1}{2} \cdot \frac{2}{56}} = \frac{6}{7} \quad \frac{1}{2} + 1\frac{1}{2}$$

25. Let  $x$  and  $y$  be the number of takes. Then

Maximise:

$$z = x + y \quad 1$$

Subject to:

$$\left. \begin{aligned} 200x + 100y &\leq 5000 \\ 25x + 50y &\leq 1000 \\ x &\geq 0, y \geq 0 \end{aligned} \right\} \quad 2$$

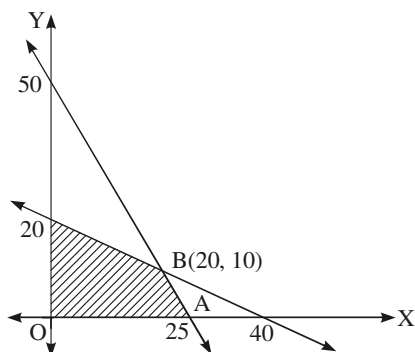

Correct figure

- at  $(20, 10)$ ,  $z = 20 + 10 = 30$  is maximum.   
at  $(25, 0)$ ,  $z = 25 + 0 = 25$    
at  $(0, 20)$ ,  $z = 20$  } 1

$$26. \quad l \times b \times 3 = 75 \Rightarrow l \times b = 25$$

1

Let C be the cost. Then

$$C = 100 (l \times b) + 100 h(b + l)$$

1

$$C = 100 \left( l \times \frac{25}{l} \right) + 300 \left( \frac{25}{l} + l \right)$$

1

$$\frac{dC}{dl} = 0 + 300 \left( \frac{-25}{l^2} + 1 \right)$$

$$\frac{dC}{dl} = 0 \Rightarrow l = 5$$

1

$$\frac{d^2C}{dl^2} > 0 \Rightarrow C \text{ is maximum when } l = 5 \Rightarrow b = 5$$

1

$$C = 100 (25) + 300(10) = \text{Rs. } 5500$$

1

OR

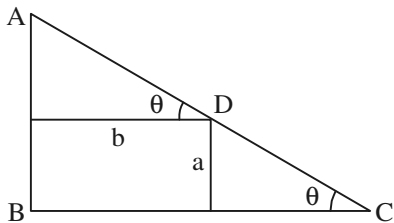

Correct figure

1

$$AD = b \sec \theta, \quad DC = a \operatorname{cosec} \theta$$

1

$$L = AC = b \sec \theta + a \operatorname{cosec} \theta$$

1

$$\frac{dL}{d\theta} = b \sec \theta \tan \theta - a \operatorname{cosec} \theta \cot \theta$$

1

$$\frac{dL}{d\theta} = 0 \Rightarrow \tan^3 \theta = \frac{a}{b}$$

1

$$\frac{d^2L}{d\theta^2} > 0 \Rightarrow \text{minima}$$

$$L = \frac{b \cdot \sqrt{a^{2/3} + b^{2/3}}}{b^{1/3}} + \frac{a \sqrt{a^{2/3} + b^{2/3}}}{a^{1/3}}$$

1

$$\Rightarrow L = (a^{2/3} + b^{2/3})^{2/3}$$

QUESTION PAPER CODE 65/1/2  
**EXPECTED ANSWER/VALUE POINTS**  
**SECTION A**

	Marks
1. $1 \cdot y + x \frac{dy}{dx} = -c \sin x \Rightarrow x \frac{dy}{dx} + y + xy \tan x = 0$	$\frac{1}{2} + \frac{1}{2}$
2. order = 2, degree = 3, sum = 2 + 3 = 5	$\frac{1}{2} + \frac{1}{2}$
3. $\hat{a} = \frac{1}{\sqrt{5}}\hat{i} - \frac{2}{\sqrt{5}}\hat{j}$ then $7\hat{a} = \frac{7}{\sqrt{5}}\hat{i} - \frac{14}{\sqrt{5}}\hat{j}$	$\frac{1}{2} + \frac{1}{2}$
4. $(\sqrt{2}\vec{a} - \vec{b}) \cdot (\sqrt{2}\vec{a} - \vec{b}) = 1 \Rightarrow \theta = \frac{\pi}{4}$	$\frac{1}{2} + \frac{1}{2}$
5. $\cos^2 \alpha + \cos^2 \beta + \cos^2 \gamma = 1 \Rightarrow \sin^2 \alpha + \sin^2 \beta + \sin^2 \gamma = 2$	$\frac{1}{2} + \frac{1}{2}$
6. $AB = \begin{bmatrix} -1 & 5 \\ 4 & 8 \end{bmatrix} \Rightarrow  AB  = -28$	$\frac{1}{2} + \frac{1}{2}$

**SECTION B**

7. $y = \frac{x \cos^{-1} x}{\sqrt{1-x^2}} - \log \sqrt{1-x^2}$	
$\frac{dy}{dx} = \frac{\sqrt{1-x^2} \cdot \left(1 \cos^{-1} x - \frac{x}{\sqrt{1-x^2}}\right) - \frac{x \cos^{-1} x (-2x)}{2\sqrt{1-x^2}} + \frac{2x}{2(1-x^2)}}{1-x^2}$	1+1
$= \frac{\sqrt{1-x^2} \cos^{-1} x - x + \frac{x^2 \cos^{-1} x}{1-x^2} + \frac{x}{1-x^2}}{1-x^2}$	1
$= \frac{(1-x^2) \cos^{-1} x + x^2 \cos^{-1} x}{(1-x^2)^{3/2}} = \frac{\cos^{-1} x}{(1-x^2)^{3/2}}$	1

8.  $y = (\sin x)^x + \sin^{-1} \sqrt{x}$

$$\Rightarrow y = e^{x \log \sin x} + \sin^{-1} \sqrt{x} \quad 1$$

$$\Rightarrow \frac{dy}{dx} = e^{x \log \sin x} [\log \sin x + x \cot x] + \frac{1}{2\sqrt{x} \sqrt{1-x}} \quad 1\frac{1}{2}$$

$$\Rightarrow \frac{dy}{dx} = (\sin x)^x (\log \sin x + x \cot x) + \frac{1}{2\sqrt{x} \sqrt{1-x}} \quad 1\frac{1}{2}$$

9.  $x = a \sec^3 \theta$

$$\frac{dx}{d\theta} = 3a \sec^3 \theta \tan \theta \quad \frac{1}{2}$$

$$y = a \tan^3 \theta$$

$$\frac{dy}{d\theta} = 3a \tan^2 \theta \sec^2 \theta \quad \frac{1}{2}$$

$$\frac{dy}{dx} = \frac{3a \tan^2 \theta \sec^2 \theta}{3a \sec^3 \theta \tan \theta} = \sin \theta \quad 1$$

$$\frac{d^2y}{dx^2} = \cos \theta \cdot \frac{d\theta}{dx} = \frac{\cos \theta}{3a \sec^3 \theta \tan \theta} = \frac{\cos^4 \theta}{3a \tan \theta} \quad 1$$

$$\left. \frac{d^2y}{dx^2} \right]_{\theta = \frac{\pi}{4}} = \frac{1}{12a} \quad 1$$

10.  $\int \frac{e^x(x^2+1)}{(x+1)^2} dx$

$$= \int e^x \left[ \frac{(x^2-1)+2}{(x+1)^2} \right] dx \quad 1$$

$$= \int e^x \left[ \frac{x-1}{x+1} + \frac{2}{(x+1)^2} \right] dx \quad 1$$

$$= \frac{x-1}{x+1} \cdot e^x - \int \frac{2}{(x+1)^2} e^x dx + \int \frac{2}{(x+1)^2} e^x dx \quad 1$$

$$= \frac{e^x(x-1)}{x+1} + C \quad 1$$

11. System of equation is

$$3x + y + 2z = 1100, x + 2y + 3z = 1400, x + y + z = 600 \quad 1\frac{1}{2}$$

(i) Matrix equation is

$$\begin{bmatrix} 3 & 1 & 2 \\ 1 & 2 & 3 \\ 1 & 1 & 1 \end{bmatrix} \begin{bmatrix} x \\ y \\ z \end{bmatrix} = \begin{bmatrix} 1100 \\ 1400 \\ 600 \end{bmatrix} \quad 1$$

(ii)  $|A| = -3 \neq 0$ , system of equations can be solved.  $\frac{1}{2}$

(iii) Any one value with reason.  $1$

$$12. [2x \quad 3] \begin{bmatrix} 1 & 2 \\ -3 & 0 \end{bmatrix} \begin{bmatrix} x \\ 3 \end{bmatrix} = 0$$

$$[2x-9 \quad 4x] \begin{bmatrix} x \\ 3 \end{bmatrix} = 0 \quad 1$$

$$[2x^2 - 9x + 12x] = [0] \Rightarrow 2x^2 + 3x = 0, x = 0 \text{ or } \frac{-3}{2} \quad 1+1+1$$

$$13. \begin{vmatrix} (a+1)(a+2) & a+2 & 1 \\ (a+2)(a+3) & a+3 & 1 \\ (a+3)(a+4) & a+4 & 1 \end{vmatrix}$$

$$= \begin{vmatrix} (a+1)(a+2) & a+2 & 1 \\ 2(a+2) & 1 & 0 \\ 4a+10 & 2 & 0 \end{vmatrix} \begin{matrix} \\ R_2 \rightarrow R_2 - R_1 \\ R_3 \rightarrow R_3 - R_1 \end{matrix} \quad 1+1$$

$$= 4a + 8 - 4a - 10 = -2. \quad 1+1$$

$$14. I = \int_0^{\pi/2} \frac{1}{1 + \sqrt{\tan x}} dx$$

$$I = \int_0^{\pi/2} \frac{1}{1 + \sqrt{\tan(\pi/2 - x)}} dx = \int_0^{\pi/2} \frac{1}{1 + \sqrt{\cot x}} dx = \int_0^{\pi/2} \frac{\sqrt{\tan x}}{1 + \sqrt{\tan x}} dx \quad 1\frac{1}{2}$$

$$\Rightarrow 2I = \int_0^{\pi/2} \frac{1 + \sqrt{\tan x}}{1 + \sqrt{\tan x}} dx = \int_0^{\pi/2} 1 \cdot dx = \frac{\pi}{2} \quad 1\frac{1}{2}$$

$$\Rightarrow I = \frac{\pi}{4} \quad 1$$

$$15. \frac{x}{(x-1)^2(x+2)} = \frac{A}{x-1} + \frac{B}{(x-1)^2} + \frac{C}{x+2} \quad \frac{1}{2}$$

$$A = \frac{2}{9}, B = \frac{1}{3}, C = -\frac{2}{9} \quad 1\frac{1}{2}$$

$$\int \frac{x}{(x-1)^2(x+2)} dx = \int \frac{2}{9(x-1)} dx + \int \frac{1}{3(x-1)^2} dx - \int \frac{2}{9(x+2)} dx \quad 1\frac{1}{2}$$

$$= \frac{2}{9} \log|x-1| - \frac{1}{3(x-1)} - \frac{2}{9} \log|x+2| + C \quad 1\frac{1}{2}$$

16. Let X be the number of defective bulbs. Then

$$X = 0, 1, 2 \quad 1$$

$$P(X=0) = \frac{10C_2}{15C_2} = \frac{3}{7}, \quad P(X=1) = \frac{10C_1 \cdot 5C_1}{15C_2} = \frac{10}{21} \quad 1+1$$

$$P(X=2) = \frac{5C_2}{15C_2} = \frac{2}{21} \quad 1$$

X	0	1	2
P(X)	$\frac{3}{7}$	$\frac{10}{21}$	$\frac{2}{21}$

OR

$E_1$ : Problem is solved by A.

$E_2$ : Problem is solved by B.

$$P(E_1) = \frac{1}{2}, P(E_2) = \frac{1}{3}, P(\bar{E}_1) = \frac{1}{2}, P(\bar{E}_2) = \frac{2}{3} \quad 1$$

$$P(E_1 \cap E_2) = P(E_1) \cdot P(E_2) = \frac{1}{6}$$

$$P(\text{problem is solved}) = 1 - P(\bar{E}_1) \cdot P(\bar{E}_2) = 1 - \frac{1}{2} \cdot \frac{2}{3} = \frac{2}{3} \quad 1\frac{1}{2}$$

$$P(\text{one of them is solved}) = P(E_1)P(\bar{E}_2) + P(\bar{E}_1)P(E_2)$$

$$= \frac{1}{2} \cdot \frac{2}{3} + \frac{1}{2} \cdot \frac{1}{3} = \frac{1}{2} \quad 1\frac{1}{2}$$

$$17. \left. \begin{aligned} \overline{AB} &= -4\hat{i} - 6\hat{j} - 2\hat{k} \\ \overline{AC} &= -\hat{i} + (\lambda - 5)\hat{j} + 3\hat{k} \\ \overline{AD} &= -8\hat{i} - \hat{j} + 3\hat{k} \end{aligned} \right\} \quad 1\frac{1}{2}$$

$$\overline{AB} \cdot (\overline{AC} \times \overline{AD}) = \begin{vmatrix} -4 & -6 & -2 \\ -1 & \lambda - 5 & 3 \\ -8 & -1 & 3 \end{vmatrix} = 0 \quad 1$$

$$-4(3\lambda - 12) + 6(21) - 2(8\lambda - 39) = 0 \Rightarrow \lambda = 9 \quad 1\frac{1}{2}$$

$$18. \left. \begin{aligned} \bar{a}_1 &= \hat{i} + 2\hat{j} + \hat{k}, \bar{b}_1 = \hat{i} - \hat{j} + \hat{k} \\ \bar{a}_2 &= 2\hat{i} - \hat{j} - \hat{k}, \bar{b}_2 = 2\hat{i} + \hat{j} + 2\hat{k} \end{aligned} \right\} \quad 1$$

$$\bar{a}_2 - \bar{a}_1 = \hat{i} - 3\hat{j} - 2\hat{k}, \bar{b}_1 \times \bar{b}_2 = \begin{vmatrix} \hat{i} & \hat{j} & \hat{k} \\ 1 & -1 & 1 \\ 2 & 1 & 1 \end{vmatrix} = -3\hat{i} + 3\hat{k} \quad \frac{1}{2} + 1$$

$$|\vec{b}_1 \times \vec{b}_2| = 3\sqrt{2}$$

1/2

$$(\vec{a}_2 - \vec{a}_1) \cdot (\vec{b}_1 - \vec{b}_2) = -3 - 6 = -9$$

$$\text{Shortest distance} = \frac{|-9|}{|3\sqrt{2}|} = \frac{3\sqrt{2}}{2}$$

1

19.  $\tan^{-1} 2x + \tan^{-1} 3x = \frac{\pi}{4}$

$$\tan^{-1} \left( \frac{5x}{1-6x^2} \right) = \frac{\pi}{4}$$

1

$$\frac{5x}{1-6x^2} = 1$$

1

$$\Rightarrow 6x^2 + 5x - 1 = 0$$

1

$$\Rightarrow x = \frac{1}{6}, x = -1 \text{ (rejected)}$$

1

OR

$$\sin^{-1} \frac{5}{13} = \tan^{-1} \frac{5}{12}$$

1

$$\cos^{-1} \frac{3}{5} = \tan^{-1} \frac{4}{3}$$

1

$$\text{R.H.S.} = \sin^{-1} \frac{5}{13} + \cos^{-1} \frac{3}{5} = \tan^{-1} \frac{5}{12} + \tan^{-1} \frac{4}{3}$$

$$= \tan \left( \frac{\frac{5}{12} + \frac{4}{3}}{1 - \frac{5}{12} \cdot \frac{4}{3}} \right)$$

1

$$= \tan^{-1} \frac{63}{16}$$

1



**SECTION C**

20.

Let  $x$  and  $y$  be the number of takes. Then

Maximise:

$$z = x + y$$

1

Subject to:

$$200x + 100y \leq 5000$$

$$25x + 50y \leq 1000$$

$$x \geq 0, y \geq 0$$

2

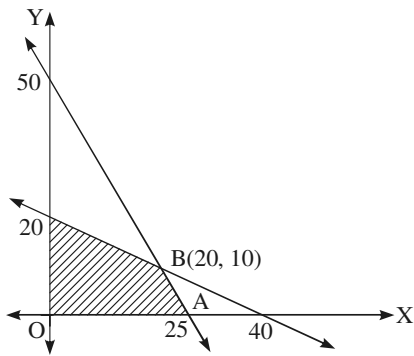

Correct figure

2

at  $(20, 10)$ ,  $z = 20 + 10 = 30$  is maximum.

at  $(25, 0)$ ,  $z = 25 + 0 = 25$

at  $(0, 20)$ ,  $z = 20$

1

21.  $l \times b \times 3 = 75 \Rightarrow l \times b = 25$

1

Let  $C$  be the cost. Then

$$C = 100(l \times b) + 100h(b + l)$$

1

$$C = 100\left(l \times \frac{25}{l}\right) + 300\left(\frac{25}{l} + l\right)$$

1

$$\frac{dC}{dl} = 0 + 300\left(\frac{-25}{l^2} + 1\right)$$

$$\frac{dC}{dl} = 0 \Rightarrow l = 5$$

1

$$\frac{d^2C}{dl^2} > 0 \Rightarrow C \text{ is maximum when } l = 5 \Rightarrow b = 5$$

1

$$C = 100(25) + 300(10) = \text{Rs. } 5500$$

1

OR

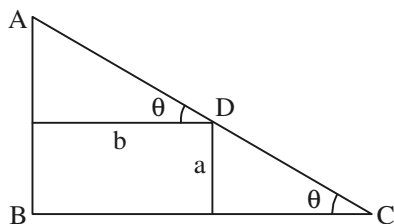

Correct figure 1

$$AD = b \sec \theta, DC = a \operatorname{cosec} \theta \quad 1$$

$$L = AC = b \sec \theta + a \operatorname{cosec} \theta \quad 1$$

$$\frac{dL}{d\theta} = b \sec \theta \tan \theta - a \operatorname{cosec} \theta \cot \theta \quad 1$$

$$\frac{dL}{d\theta} = 0 \Rightarrow \tan^3 \theta = \frac{a}{b} \quad 1$$

$$\frac{d^2L}{d\theta^2} > 0 \Rightarrow \text{minima}$$

$$L = \frac{b \cdot \sqrt{a^{2/3} + b^{2/3}}}{b^{1/3}} + \frac{a \sqrt{a^{2/3} + b^{2/3}}}{a^{1/3}} \quad 1$$

$$\Rightarrow L = (a^{2/3} + b^{2/3})^{2/3}$$

22.  $(a, b) * (c, d) = (a + c, b + d) = (c + a, d + b) = (c, d) * (a, b) \therefore *$  is commutative 1½

$$[(a, b) * (c, d)] * (e, f) = (a + c, b + d) * (e, f)$$

$$= (a + c + e, b + d + f) = (a, b) * (c + e, d + f) \quad 1$$

$$= (a, b) * [(c, d) * (e, f)] \therefore * \text{ is associate} \quad 1\frac{1}{2}$$

Let  $(e, e')$  be the identity

$$(a, b) * (e, e') = (a, b) \Rightarrow (a + e, b + e') = (a, b) \Rightarrow e = 0, e' = 0$$

$\Rightarrow$  Identity element is  $(0, 0)$  2

23.

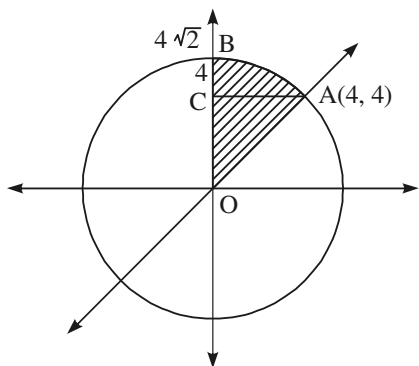

$$x^2 + y^2 = 32; y = x \text{ point of intersection is } y = 4 \quad \frac{1}{2}$$

Correct figure 1

$$\text{Required Area} = \int_0^4 y \, dy + \int_4^{4\sqrt{2}} \sqrt{32 - y^2} \, dy \quad 1\frac{1}{2}$$

$$= \left[ \frac{y^2}{2} \right]_0^4 + \left[ \frac{y}{2} \sqrt{32-y^2} + 16 \sin^{-1} \frac{y}{4\sqrt{2}} \right]_4^{4\sqrt{2}} \quad 1\frac{1}{2}$$

$$= 8 + \left( 0 + 16 \cdot \frac{\pi}{2} \right) - \left( 8 + 16 \cdot \frac{\pi}{2} \right) = 4\pi \quad 1\frac{1}{2}$$

24.  $x \frac{dy}{dx} + y - x + xy \cot x = 0 \Rightarrow \frac{dy}{dx} + \left( \frac{1}{x} + \cot x \right) y = 1 \quad \frac{1}{2}$

I.F. =  $e^{\int \left( \frac{1}{x} + \cot x \right) dx} = x \sin x \quad 1$

Solution:  $y \cdot x \sin x = \int 1 \cdot x \sin x dx \quad 1\frac{1}{2}$

$\Rightarrow yx \sin x = -x \cos x + \sin x + C \quad 1$

when

$x = \frac{\pi}{2}, y = 0$ , we have  $C = -1 \quad 1$

$yx \sin x + x \cos x - \sin x = 1 \quad 1$

OR

$x^2 dy + (xy + y^2) dx = 0 \Rightarrow \frac{dy}{dx} = \frac{-(xy + y^2)}{x^2} \quad 1$

Put  $y = vx \Rightarrow \frac{dy}{dx} = v + x \frac{dv}{dx} \quad 1$

$\Rightarrow v + x \frac{dv}{dx} = -(v + v^2) \Rightarrow \frac{dv}{v^2 + 2v} = -\frac{dx}{x}$

$\Rightarrow \int \frac{dv}{(v+1)^2 - (1)^2} - \int \frac{dx}{x} \Rightarrow \frac{1}{2} \log \frac{v}{v+2} = -\log x + \log C \quad 1$

$\Rightarrow \frac{C}{x} = \sqrt{\frac{y}{y+x}} \quad 1$

If  $x = 1, y = 1$ , then  $C = \frac{1}{\sqrt{3}}$  1

$\Rightarrow \frac{1}{\sqrt{3}x} = \sqrt{\frac{y}{y+x}}$  1

25. Plane passing through the intersection of given planes:

$(x + y + z - 1) + \lambda(2x + 3y + 4z - 5) = 0$  1

$(1 + 2\lambda)x + (1 + 3\lambda)y + (1 + 4\lambda)z + (-1 - 5\lambda) = 0$  1½

Now  $(1 + 2\lambda)1 + (1 + 3\lambda)(-1) + (1 + 4\lambda)1 = 0$  1½

$\Rightarrow \lambda = -\frac{1}{3}$  1

Equation of required plane is

$\Rightarrow x - z + 2 = 0$  1

26.  $E_1$ : First bag is selected. }  
 $E_2$ : Second bag is selected. } 1  
A: both balls are red. }

$P(E_1) = \frac{1}{2}, P(E_2) = \frac{1}{2}, P\left(\frac{A}{E_1}\right) = \frac{12}{56}, P\left(\frac{A}{E_2}\right) = \frac{2}{56}$  ½ + ½ + 1 + 1

$P\left(\frac{E_1}{A}\right) = \frac{P(E_1) P\left(\frac{A}{E_1}\right)}{P(E_1) P\left(\frac{A}{E_1}\right) + P(E_2) P\left(\frac{A}{E_2}\right)} = \frac{\frac{1}{2} \times \frac{12}{56}}{\frac{1}{2} \times \frac{12}{56} + \frac{1}{2} \times \frac{2}{56}} = \frac{6}{7}$  ½ + 1½

QUESTION PAPER CODE 65/1/3  
**EXPECTED ANSWER/VALUE POINTS**  
**SECTION A**

	Marks
1. $\cos^2 \alpha + \cos^2 \beta + \cos^2 \gamma = 1 \Rightarrow \sin^2 \alpha + \sin^2 \beta + \sin^2 \gamma = 2$	$\frac{1}{2} + \frac{1}{2}$
2. $AB = \begin{bmatrix} -1 & 5 \\ 4 & 8 \end{bmatrix} \Rightarrow  AB  = -28$	$\frac{1}{2} + \frac{1}{2}$
3. $1 \cdot y + x \frac{dy}{dx} = -c \sin x \Rightarrow x \frac{dy}{dx} + y + xy \tan x = 0$	$\frac{1}{2} + \frac{1}{2}$
4. order = 2, degree = 3, sum = 2 + 3 = 5	$\frac{1}{2} + \frac{1}{2}$
5. $\hat{a} = \frac{1}{\sqrt{5}}\hat{i} - \frac{2}{\sqrt{5}}\hat{j}$ then $7\hat{a} = \frac{7}{\sqrt{5}}\hat{i} - \frac{14}{\sqrt{5}}\hat{j}$	$\frac{1}{2} + \frac{1}{2}$
6. $(\sqrt{2}\vec{a} - \vec{b}) \cdot (\sqrt{2}\vec{a} - \vec{b}) = 1 \Rightarrow \theta = \frac{\pi}{4}$	$\frac{1}{2} + \frac{1}{2}$

**SECTION B**

7. $\frac{x}{(x-1)^2(x+2)} = \frac{A}{x-1} + \frac{B}{(x-1)^2} + \frac{C}{x+2}$	$\frac{1}{2}$
$A = \frac{2}{9}, B = \frac{1}{3}, C = -\frac{2}{9}$	$1\frac{1}{2}$
$\int \frac{x}{(x-1)^2(x+2)} dx = \int \frac{2}{9(x-1)} dx + \int \frac{1}{3(x-1)^2} dx - \int \frac{2}{9(x+2)} dx$	$1\frac{1}{2}$
$= \frac{2}{9} \log  x-1  - \frac{1}{3(x-1)} - \frac{2}{9} \log  x+2  + C$	$1\frac{1}{2}$
8. Let X be the number of defective bulbs. Then	
$X = 0, 1, 2$	1

$$P(X=0) = \frac{10C_2}{15C_2} = \frac{3}{7}, \quad P(X=1) = \frac{10C_1 \cdot 5C_1}{15C_2} = \frac{10}{21} \quad 1+1$$

$$P(X=2) = \frac{5C_2}{15C_2} = \frac{2}{21} \quad 1$$

X	0	1	2
P(X)	$\frac{3}{7}$	$\frac{10}{21}$	$\frac{2}{21}$

OR

$E_1$ : Problem is solved by A.

$E_2$ : Problem is solved by B.

$$P(E_1) = \frac{1}{2}, \quad P(E_2) = \frac{1}{3}, \quad P(\bar{E}_1) = \frac{1}{2}, \quad P(\bar{E}_2) = \frac{2}{3} \quad 1$$

$$P(E_1 \cap E_2) = P(E_1) \cdot P(E_2) = \frac{1}{6}$$

$$P(\text{problem is solved}) = 1 - P(\bar{E}_1) \cdot P(\bar{E}_2) = 1 - \frac{1}{2} \cdot \frac{2}{3} = \frac{2}{3} \quad 1\frac{1}{2}$$

$$P(\text{one of them is solved}) = P(E_1)P(\bar{E}_2) + P(\bar{E}_1)P(E_2)$$

$$= \frac{1}{2} \cdot \frac{2}{3} + \frac{1}{2} \cdot \frac{1}{3} = \frac{1}{2} \quad 1\frac{1}{2}$$

$$9. \left. \begin{aligned} \overline{AB} &= -4\hat{i} - 6\hat{j} - 2\hat{k} \\ \overline{AC} &= -\hat{i} + (\lambda - 5)\hat{j} + 3\hat{k} \\ \overline{AD} &= -8\hat{i} - \hat{j} + 3\hat{k} \end{aligned} \right\} \quad 1\frac{1}{2}$$

$$\overline{AB} \cdot (\overline{AC} \times \overline{AD}) = \begin{vmatrix} -4 & -6 & -2 \\ -1 & \lambda - 5 & 3 \\ -8 & -1 & 3 \end{vmatrix} = 0 \quad 1$$

$$-4(3\lambda - 12) + 6(21) - 2(8\lambda - 39) = 0 \Rightarrow \lambda = 9$$

1½

$$10. \left. \begin{aligned} \vec{a}_1 &= \hat{i} + 2\hat{j} + \hat{k}, \vec{b}_1 = \hat{i} - \hat{j} + \hat{k} \\ \vec{a}_2 &= 2\hat{i} - \hat{j} - \hat{k}, \vec{b}_2 = 2\hat{i} + \hat{j} + 2\hat{k} \end{aligned} \right\} \quad 1$$

$$\vec{a}_2 - \vec{a}_1 = \hat{i} - 3\hat{j} - 2\hat{k}, \vec{b}_1 \times \vec{b}_2 = \begin{vmatrix} \hat{i} & \hat{j} & \hat{k} \\ 1 & -1 & 1 \\ 2 & 1 & 1 \end{vmatrix} = -3\hat{i} + 3\hat{k} \quad \frac{1}{2} + 1$$

$$|\vec{b}_1 \times \vec{b}_2| = 3\sqrt{2} \quad \frac{1}{2}$$

$$(\vec{a}_2 - \vec{a}_1) \cdot (\vec{b}_1 - \vec{b}_2) = -3 - 6 = -9$$

$$\text{Shortest distance} = \left| \frac{-9}{3\sqrt{2}} \right| = \frac{3\sqrt{2}}{2} \quad 1$$

$$11. \tan^{-1} 2x + \tan^{-1} 3x = \frac{\pi}{4}$$

$$\tan^{-1} \left( \frac{5x}{1-6x^2} \right) = \frac{\pi}{4} \quad 1$$

$$\frac{5x}{1-6x^2} = 1 \quad 1$$

$$\Rightarrow 6x^2 + 5x - 1 = 0 \quad 1$$

$$\Rightarrow x = \frac{1}{6}, x = -1 \text{ (rejected)} \quad 1$$

OR

$$\sin^{-1} \frac{5}{13} = \tan^{-1} \frac{5}{12} \quad 1$$

$$\cos^{-1} \frac{3}{5} = \tan^{-1} \frac{4}{3} \quad 1$$

$$\text{R.H.S.} = \sin^{-1} \frac{5}{13} + \cos^{-1} \frac{3}{5} = \tan^{-1} \frac{5}{12} + \tan^{-1} \frac{4}{3}$$

$$= \tan \left( \frac{\frac{5}{12} + \frac{4}{3}}{1 - \frac{5}{12} \cdot \frac{4}{3}} \right) \quad 1$$

$$= \tan^{-1} \frac{63}{16} \quad 1$$

$$12. \quad y = \frac{x \cos^{-1} x}{\sqrt{1-x^2}} - \log \sqrt{1-x^2}$$

$$\frac{dy}{dx} = \frac{\sqrt{1-x^2} \cdot \left( 1 \cos^{-1} x - \frac{x}{\sqrt{1-x^2}} \right) - \frac{x \cos^{-1} x (-2x)}{2\sqrt{1-x^2}} + \frac{2x}{2(1-x^2)}}{1-x^2} \quad 1+1$$

$$= \frac{\sqrt{1-x^2} \cos^{-1} x - x + \frac{x^2 \cos^{-1} x}{1-x^2}}{1-x^2} + \frac{x}{1-x^2} \quad 1$$

$$= \frac{(1-x^2) \cos^{-1} x + x^2 \cos^{-1} x}{(1-x^2)^{3/2}} = \frac{\cos^{-1} x}{(1-x^2)^{3/2}} \quad 1$$

$$13. \quad y = (\sin x)^x + \sin^{-1} \sqrt{x}$$

$$\Rightarrow y = e^{x \log \sin x} + \sin^{-1} \sqrt{x} \quad 1$$

$$\Rightarrow \frac{dy}{dx} = e^{x \log \sin x} [\log \sin x + x \cot x] + \frac{1}{2\sqrt{x} \sqrt{1-x}} \quad 1\frac{1}{2}$$

$$\Rightarrow \frac{dy}{dx} = (\sin x)^x (\log \sin x + x \cot x) + \frac{1}{2\sqrt{x} \sqrt{1-x}} \quad 1\frac{1}{2}$$

$$14. \quad x = a \sec^3 \theta$$

$$\frac{dx}{d\theta} = 3a \sec^3 \theta \tan \theta \quad \frac{1}{2}$$



$$y = a \tan^3 \theta$$

$$\frac{dy}{d\theta} = 3a \tan^2 \theta \sec^2 \theta \quad \frac{1}{2}$$

$$\frac{dy}{dx} = \frac{3a \tan^2 \theta \sec^2 \theta}{3a \sec^3 \theta \tan \theta} = \sin \theta \quad 1$$

$$\frac{d^2y}{dx^2} = \cos \theta \cdot \frac{d\theta}{dx} = \frac{\cos \theta}{3a \sec^3 \theta \tan \theta} = \frac{\cos^4 \theta}{3a \tan \theta} \quad 1$$

$$\left. \frac{d^2y}{dx^2} \right]_{\theta = \frac{\pi}{4}} = \frac{1}{12a} \quad 1$$

15.  $\int \frac{e^x(x^2+1)}{(x+1)^2} dx$

$$= \int e^x \left[ \frac{(x^2-1)+2}{(x+1)^2} \right] dx \quad 1$$

$$= \int e^x \left[ \frac{x-1}{x+1} + \frac{2}{(x+1)^2} \right] dx \quad 1$$

$$= \frac{x-1}{x+1} \cdot e^x - \int \frac{2}{(x+1)^2} e^x dx + \int \frac{2}{(x+1)^2} e^x dx \quad 1$$

$$= \frac{e^x(x-1)}{x+1} + C \quad 1$$

16. System of equation is

$$3x + y + 2z = 1100, x + 2y + 3z = 1400, x + y + z = 600 \quad 1\frac{1}{2}$$

(i) Matrix equation is

$$\begin{bmatrix} 3 & 1 & 2 \\ 1 & 2 & 3 \\ 1 & 1 & 1 \end{bmatrix} \begin{bmatrix} x \\ y \\ z \end{bmatrix} = \begin{bmatrix} 1100 \\ 1400 \\ 600 \end{bmatrix} \quad 1$$

(ii)  $|A| = -3 \neq 0$ , system of equations can be solved. 1/2

(iii) Any one value with reason. 1

17.  $[2x \quad 3] \begin{bmatrix} 1 & 2 \\ -3 & 0 \end{bmatrix} \begin{bmatrix} x \\ 3 \end{bmatrix} = 0$

$$[2x - 9 \quad 4x] \begin{bmatrix} x \\ 3 \end{bmatrix} = 0 \quad \text{1}$$

$$[2x^2 - 9x + 12x] = [0] \Rightarrow 2x^2 + 3x = 0, x = 0 \text{ or } \frac{-3}{2} \quad \text{1+1+1}$$

18.  $\begin{vmatrix} (a+1)(a+2) & a+2 & 1 \\ (a+2)(a+3) & a+3 & 1 \\ (a+3)(a+4) & a+4 & 1 \end{vmatrix}$

$$= \begin{vmatrix} (a+1)(a+2) & a+2 & 1 \\ 2(a+2) & 1 & 0 \\ 4a+10 & 2 & 0 \end{vmatrix} \begin{matrix} \\ R_2 \rightarrow R_2 - R_1 \\ R_3 \rightarrow R_3 - R_1 \end{matrix} \quad \text{1+1}$$

$$= 4a + 8 - 4a - 10 = -2. \quad \text{1+1}$$

19.  $I = \int_0^{\pi/2} \frac{1}{1 + \sqrt{\tan x}} dx$

$$I = \int_0^{\pi/2} \frac{1}{1 + \sqrt{\tan(\pi/2 - x)}} dx = \int_0^{\pi/2} \frac{1}{1 + \sqrt{\cot x}} dx = \int_0^{\pi/2} \frac{\sqrt{\tan x}}{1 + \sqrt{\tan x}} dx \quad \text{1 1/2}$$

$$\Rightarrow 2I = \int_0^{\pi/2} \frac{1 + \sqrt{\tan x}}{1 + \sqrt{\tan x}} dx = \int_0^{\pi/2} 1 \cdot dx = \frac{\pi}{2} \quad \text{1 1/2}$$

$$\Rightarrow I = \frac{\pi}{4} \quad \text{1}$$

**SECTION C**

20. Plane passing through the intersection of given planes:

$$(x + y + z - 1) + \lambda(2x + 3y + 4z - 5) = 0 \quad 1$$

$$(1 + 2\lambda)x + (1 + 3\lambda)y + (1 + 4\lambda)z + (-1 - 5\lambda) = 0 \quad 1\frac{1}{2}$$

$$\text{Now } (1 + 2\lambda) \cdot 1 + (1 + 3\lambda)(-1) + (1 + 4\lambda) \cdot 1 = 0 \quad 1\frac{1}{2}$$

$$\Rightarrow \lambda = -\frac{1}{3} \quad 1$$

Equation of required plane is

$$\Rightarrow x - z + 2 = 0 \quad 1$$

21.  $E_1$ : First bag is selected. }

$E_2$ : Second bag is selected. }

A: both balls are red. }

1

$$P(E_1) = \frac{1}{2}, P(E_2) = \frac{1}{2}, P\left(\frac{A}{E_1}\right) = \frac{12}{56}, P\left(\frac{A}{E_2}\right) = \frac{2}{56} \quad \frac{1}{2} + \frac{1}{2} + 1 + 1$$

$$P\left(\frac{E_1}{A}\right) = \frac{P(E_1) P\left(\frac{A}{E_1}\right)}{P(E_1) P\left(\frac{A}{E_1}\right) + P(E_2) P\left(\frac{A}{E_2}\right)} = \frac{\frac{1}{2} \times \frac{12}{56}}{\frac{1}{2} \times \frac{12}{56} + \frac{1}{2} \times \frac{2}{56}} = \frac{6}{7} \quad \frac{1}{2} + 1\frac{1}{2}$$

22.

Let x and y be the number of takes. Then

Maximise:

$$z = x + y \quad 1$$

Subject to:

$$\left. \begin{aligned} 200x + 100y &\leq 5000 \\ 25x + 50y &\leq 1000 \\ x \geq 0, y &\geq 0 \end{aligned} \right\} \quad 2$$

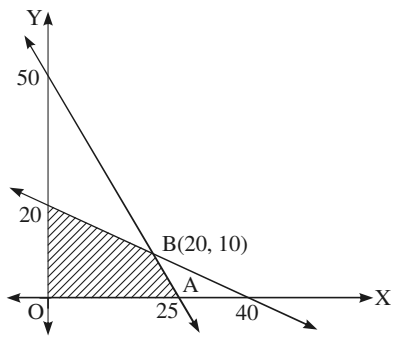

Correct figure

2

at (20, 10),  $z = 20 + 10 = 30$  is maximum.

at (25, 0),  $z = 25 + 0 = 25$

at (0, 20),  $z = 20$

1

23.  $l \times b \times 3 = 75 \Rightarrow l \times b = 25$

1

Let C be the cost. Then

$$C = 100(l \times b) + 100h(b + l)$$

1

$$C = 100\left(l \times \frac{25}{l}\right) + 300\left(\frac{25}{l} + l\right)$$

1

$$\frac{dC}{dl} = 0 + 300\left(\frac{-25}{l^2} + 1\right)$$

$$\frac{dC}{dl} = 0 \Rightarrow l = 5$$

1

$$\frac{d^2C}{dl^2} > 0 \Rightarrow C \text{ is maximum when } l = 5 \Rightarrow b = 5$$

1

$$C = 100(25) + 300(10) = \text{Rs. } 5500$$

1

OR

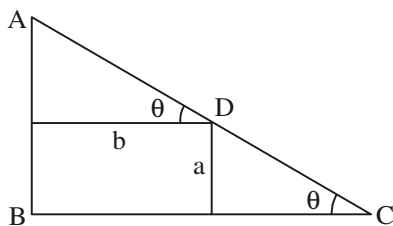

Correct figure

1

$$AD = b \sec \theta, DC = a \operatorname{cosec} \theta$$

1

$$L = AC = b \sec \theta + a \operatorname{cosec} \theta$$

1

$$\frac{dL}{d\theta} = b \sec \theta \tan \theta - a \operatorname{cosec} \theta \cot \theta$$

1

$$\frac{dL}{d\theta} = 0 \Rightarrow \tan^3 \theta = \frac{a}{b}$$

1

$$\frac{d^2L}{d\theta^2} > 0 \Rightarrow \text{minima}$$

$$\left. \begin{aligned} L &= \frac{b \cdot \sqrt{a^{2/3} + b^{2/3}}}{b^{1/3}} + \frac{a \sqrt{a^{2/3} + b^{2/3}}}{a^{1/3}} \\ \Rightarrow L &= (a^{2/3} + b^{2/3})^{2/3} \end{aligned} \right\} 1$$

24.  $(a, b) * (c, d) = (a + c, b + d) = (c + a, d + b) = (c, d) * (a, b) \therefore *$  is commutative 1½

$$[(a, b) * (c, d)] * (e, f) = (a + c, b + d) * (e, f)$$

$$= (a + c + e, b + d + f) = (a, b) * (c + e, d + f) \quad 1$$

$$= (a, b) * [(c, d) * (e, f)] \therefore *$$
 is associate 1½

Let  $(e, e')$  be the identity

$$(a, b) * (e, e') = (a, b) \Rightarrow (a + e, b + e') = (a, b) \Rightarrow e = 0, e' = 0$$

$$\Rightarrow \text{Identity element is } (0, 0) \quad 2$$

25.  $x^2 + y^2 = 32; y = x$  point of intersection is  $y = 4$  ½

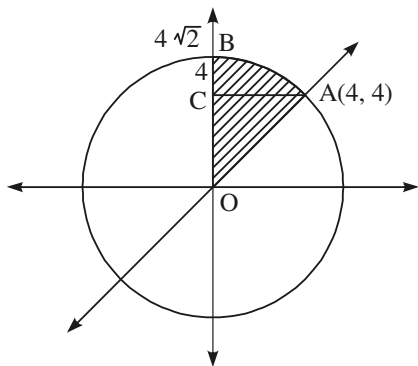

Correct figure 1

$$\text{Required Area} = \int_0^4 y \, dy + \int_4^{4\sqrt{2}} \sqrt{32 - y^2} \, dy \quad 1½$$

$$= \left[ \frac{y^2}{2} \right]_0^4 + \left[ \frac{y}{2} \sqrt{32 - y^2} + 16 \sin^{-1} \frac{y}{4\sqrt{2}} \right]_4^{4\sqrt{2}} \quad 1½$$

$$= 8 + \left( 0 + 16 \cdot \frac{\pi}{2} \right) - \left( 8 + 16 \cdot \frac{\pi}{2} \right) = 4\pi \quad 1½$$

26.  $x \frac{dy}{dx} + y - x + xy \cot x = 0 \Rightarrow \frac{dy}{dx} + \left( \frac{1}{x} + \cot x \right) y = 1$  ½

$$\text{I.F.} = e^{\int \left( \frac{1}{x} + \cot x \right) dx} = x \sin x \quad 1$$

$$\text{Solution: } y \cdot x \sin x = \int 1 \cdot x \sin x \, dx \quad 1\frac{1}{2}$$

$$\Rightarrow yx \sin x = -x \cos x + \sin x + C \quad 1$$

when

$$x = \frac{\pi}{2}, y = 0, \text{ we have } C = -1 \quad 1$$

$$yx \sin x + x \cos x - \sin x = 1 \quad 1$$

OR

$$x^2 dy + (xy + y^2) dx = 0 \Rightarrow \frac{dy}{dx} = \frac{-(xy + y^2)}{x^2} \quad 1$$

$$\text{Put } y = vx \Rightarrow \frac{dy}{dx} = v + x \frac{dv}{dx} \quad 1$$

$$\Rightarrow v + x \frac{dv}{dx} = -(v + v^2) \Rightarrow \frac{dv}{v^2 + 2v} = -\frac{dx}{x}$$

$$\Rightarrow \int \frac{dv}{(v+1)^2 - (1)^2} - \int \frac{dx}{x} \Rightarrow \frac{1}{2} \log \frac{v}{v+2} = -\log x + \log C \quad 1$$

$$\Rightarrow \frac{C}{x} = \sqrt{\frac{y}{y+x}} \quad 1$$

$$\text{If } x = 1, y = 1, \text{ then } C = \frac{1}{\sqrt{3}} \quad 1$$

$$\Rightarrow \frac{1}{\sqrt{3}x} = \sqrt{\frac{y}{y+x}} \quad 1$$