

## CIRCLES

### (A) Main Concepts and Results

- The meaning of a tangent and its point of contact on a circle.
- Tangent is perpendicular to the radius through the point of contact.
- Only two tangents can be drawn to a circle from an external point.
- Lengths of tangents from an external point to a circle are equal.

### (B) Multiple Choice Questions

Choose the correct answer from the given four options:

**Sample Question 1 :** If angle between two radii of a circle is  $130^\circ$ , the angle between the tangents at the ends of the radii is :

- (A)  $90^\circ$       (B)  $50^\circ$       (C)  $70^\circ$       (D)  $40^\circ$

**Solution :** Answer (B)

**Sample Question 2 :** In Fig. 9.1, the pair of tangents AP and AQ drawn from an external point A to a circle with centre O are perpendicular to each other and length of each tangent is 5 cm. Then the radius of the circle is

- (A) 10 cm      (B) 7.5 cm  
(C) 5 cm      (D) 2.5 cm

**Solution:** Answer (C)

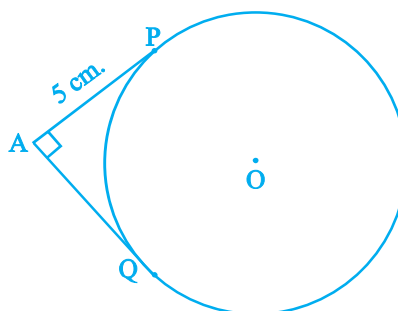

Fig. 9.1

**Sample Question 3:** In Fig. 9.2, PQ is a chord of a circle and PT is the tangent at P such that  $\angle QPT = 60^\circ$ . Then  $\angle PRQ$  is equal to

- (A)  $135^\circ$       (B)  $150^\circ$   
 (C)  $120^\circ$       (D)  $110^\circ$

**Solution :** Answer (C)

[**Hint :**  $\angle OPQ = \angle OQP = 30^\circ$ , i.e.,  $\angle POQ = 120^\circ$ . Also,  $\angle PRQ = \frac{1}{2}$  reflex  $\angle POQ$ ]

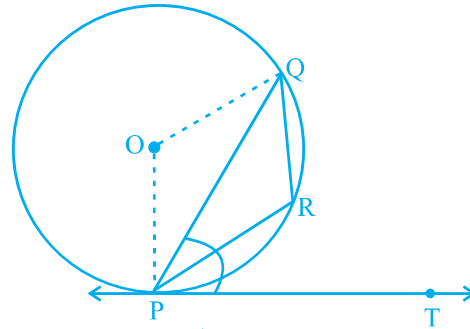

Fig. 9.2

### EXERCISE 9.1

Choose the correct answer from the given four options:

1. If radii of two concentric circles are 4 cm and 5 cm, then the length of each chord of one circle which is tangent to the other circle is

- (A) 3 cm      (B) 6 cm  
 (C) 9 cm      (D) 1 cm

2. In Fig. 9.3, if  $\angle AOB = 125^\circ$ , then  $\angle COD$  is equal to

- (A)  $62.5^\circ$       (B)  $45^\circ$   
 (C)  $35^\circ$       (D)  $55^\circ$

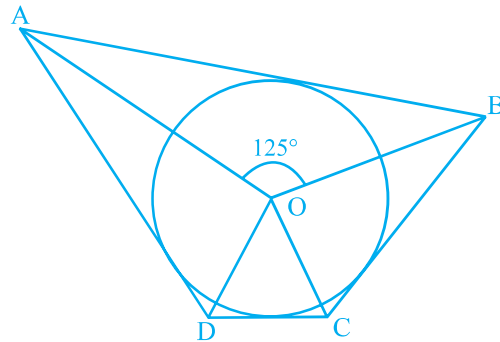

Fig. 9.3

3. In Fig. 9.4, AB is a chord of the circle and AOC is its diameter such that  $\angle ACB = 50^\circ$ . If AT is the tangent to the circle at the point A, then  $\angle BAT$  is equal to

- (A)  $65^\circ$       (B)  $60^\circ$   
 (C)  $50^\circ$       (D)  $40^\circ$

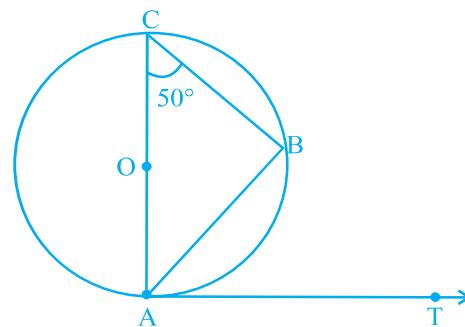

Fig. 9.4

4. From a point P which is at a distance of 13 cm from the centre O of a circle of radius 5 cm, the pair of tangents PQ and PR to the circle are drawn. Then the area of the quadrilateral PQOR is
- (A)  $60 \text{ cm}^2$  (B)  $65 \text{ cm}^2$  (C)  $30 \text{ cm}^2$  (D)  $32.5 \text{ cm}^2$
5. At one end A of a diameter AB of a circle of radius 5 cm, tangent XAY is drawn to the circle. The length of the chord CD parallel to XY and at a distance 8 cm from A is
- (A) 4 cm (B) 5 cm  
(C) 6 cm (D) 8 cm

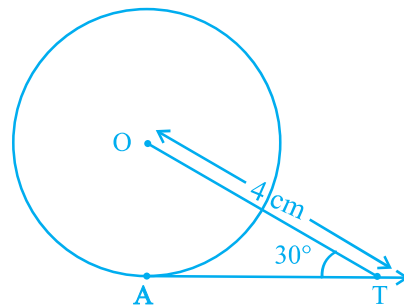

Fig. 9.5

6. In Fig. 9.5, AT is a tangent to the circle with centre O such that  $OT = 4 \text{ cm}$  and  $\angle OTA = 30^\circ$ . Then AT is equal to
- (A) 4 cm (B) 2 cm  
(C)  $2\sqrt{3} \text{ cm}$  (D)  $4\sqrt{3} \text{ cm}$

7. In Fig. 9.6, if O is the centre of a circle, PQ is a chord and the tangent PR at P makes an angle of  $50^\circ$  with PQ, then  $\angle POQ$  is equal to
- (A)  $100^\circ$  (B)  $80^\circ$   
(C)  $90^\circ$  (D)  $75^\circ$

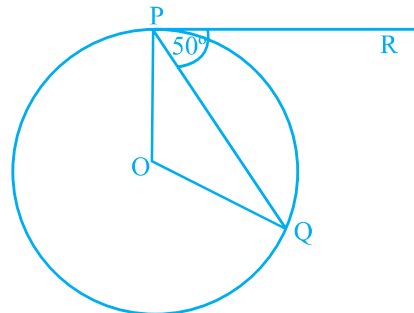

Fig. 9.6

8. In Fig. 9.7, if PA and PB are tangents to the circle with centre O such that  $\angle APB = 50^\circ$ , then  $\angle OAB$  is equal to
- (A)  $25^\circ$  (B)  $30^\circ$   
(C)  $40^\circ$  (D)  $50^\circ$

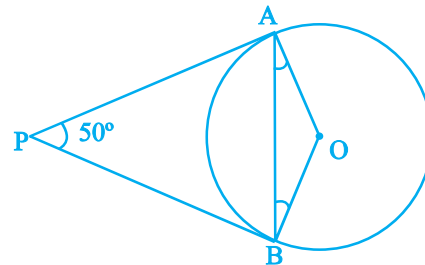

Fig. 9.7

9. If two tangents inclined at an angle  $60^\circ$  are drawn to a circle of radius 3 cm, then length of each tangent is equal to

- (A)  $\frac{3}{2}\sqrt{3}$  cm      (B) 6 cm  
 (C) 3 cm      (D)  $3\sqrt{3}$  cm

10. In Fig. 9.8, if PQR is the tangent to a circle at Q whose centre is O, AB is a chord parallel to PR and  $\angle BQR = 70^\circ$ , then  $\angle AQB$  is equal to

- (A)  $20^\circ$       (B)  $40^\circ$   
 (C)  $35^\circ$       (D)  $45^\circ$

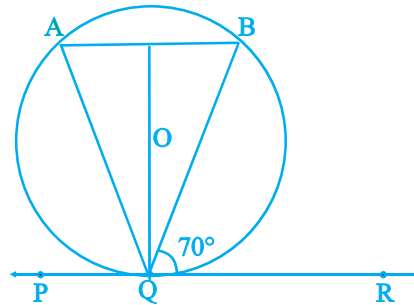

Fig. 9.8

### (C) Short Answer Questions with Reasoning

Write 'True' or 'False' and give reasons for your answer.

**Sample Question 1 :** In Fig. 9.9, BOA is a diameter of a circle and the tangent at a point P meets BA extended at T. If  $\angle PBO = 30^\circ$ , then  $\angle PTA$  is equal to  $30^\circ$ .

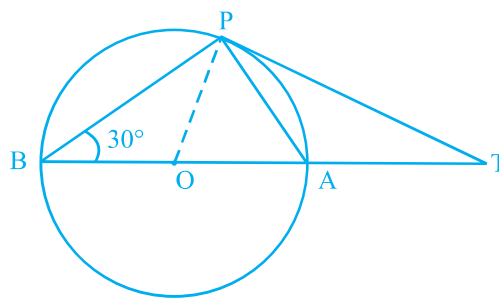

Fig. 9.9

**Solution :** True. As  $\angle BPA = 90^\circ$ ,  $\angle PAB = \angle OPA = 60^\circ$ . Also,  $OP \perp PT$ . Therefore,  $\angle APT = 30^\circ$  and  $\angle PTA = 60^\circ - 30^\circ = 30^\circ$ .

**Sample Question 2 :** In Fig. 9.10, PQL and PRM are tangents to the circle with centre O at the points Q and R, respectively and S is a point on the circle such that  $\angle SQL = 50^\circ$  and  $\angle SRM = 60^\circ$ . Then  $\angle QSR$  is equal to  $40^\circ$ .

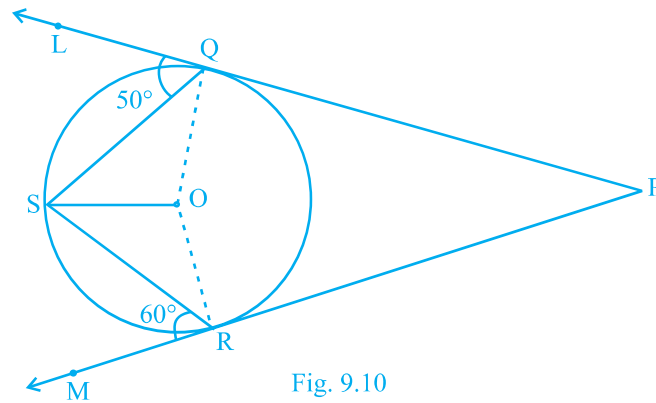

Fig. 9.10

**Solution :** False. Here  $\angle OSQ = \angle OQS = 90^\circ - 50^\circ = 40^\circ$  and  $\angle RSO = \angle SRO = 90^\circ - 60^\circ = 30^\circ$ . Therefore,  $\angle QSR = 40^\circ + 30^\circ = 70^\circ$ .

### EXERCISE 9.2

Write 'True' or 'False' and justify your answer in each of the following :

1. If a chord AB subtends an angle of  $60^\circ$  at the centre of a circle, then angle between the tangents at A and B is also  $60^\circ$ .
2. The length of tangent from an external point on a circle is always greater than the radius of the circle.
3. The length of tangent from an external point P on a circle with centre O is always less than OP.
4. The angle between two tangents to a circle may be  $0^\circ$ .
5. If angle between two tangents drawn from a point P to a circle of radius  $a$  and centre O is  $90^\circ$ , then  $OP = a\sqrt{2}$ .
6. If angle between two tangents drawn from a point P to a circle of radius  $a$  and centre O is  $60^\circ$ , then  $OP = a\sqrt{3}$ .
7. The tangent to the circumcircle of an isosceles triangle ABC at A, in which  $AB = AC$ , is parallel to BC.

8. If a number of circles touch a given line segment PQ at a point A, then their centres lie on the perpendicular bisector of PQ.
9. If a number of circles pass through the end points P and Q of a line segment PQ, then their centres lie on the perpendicular bisector of PQ.
10. AB is a diameter of a circle and AC is its chord such that  $\angle BAC = 30^\circ$ . If the tangent at C intersects AB extended at D, then  $BC = BD$ .

#### (D) Short Answer Questions

**Sample Question 1 :** If  $d_1, d_2$  ( $d_2 > d_1$ ) be the diameters of two concentric circles and  $c$  be the length of a chord of a circle which is tangent to the other circle, prove that  $d_2^2 = c^2 + d_1^2$ .

**Solution :** Let AB be a chord of a circle which touches the other circle at C. Then  $\triangle OCB$  is right triangle (see Fig.9.11). By Pythagoras theorem  $OC^2 + CB^2 = OB^2$ .

$$\text{i.e., } \left(\frac{1}{2}d_1\right)^2 + \left(\frac{1}{2}c\right)^2 = \left(\frac{1}{2}d_2\right)^2$$

(As C bisects AB)

Therefore,  $d_2^2 = c^2 + d_1^2$ .

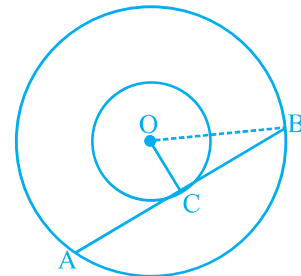

Fig. 9.11

**Sample Question 2 :** If  $a, b, c$  are the sides of a right triangle where  $c$  is the hypotenuse, prove that the radius  $r$  of the circle which touches the sides of the triangle is given by

$$r = \frac{a + b - c}{2}$$

**Solution :** Let the circle touches the sides BC, CA, AB of the right triangle ABC at D, E and F respectively, where  $BC = a$ ,  $CA = b$  and  $AB = c$  (see Fig. 9.12). Then  $AE = AF$  and  $BD = BF$ . Also  $CE = CD = r$ .

$$\text{i.e., } b - r = AF, \quad a - r = BF$$

$$\text{or } AB = c = AF + BF = b - r + a - r$$

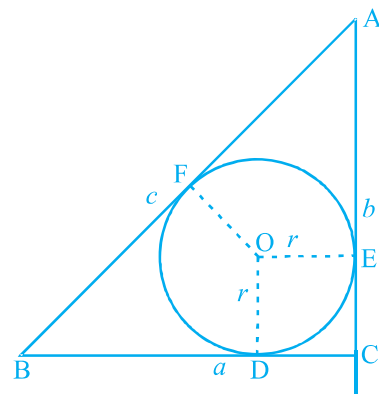

Fig. 9.12

This gives  $r = \frac{a + b + c}{2}$

### EXERCISE 9.3

1. Out of the two concentric circles, the radius of the outer circle is 5 cm and the chord AC of length 8 cm is a tangent to the inner circle. Find the radius of the inner circle.
2. Two tangents PQ and PR are drawn from an external point to a circle with centre O. Prove that QORP is a cyclic quadrilateral.
3. If from an external point B of a circle with centre O, two tangents BC and BD are drawn such that  $\angle DBC = 120^\circ$ , prove that  $BC + BD = BO$ , i.e.,  $BO = 2BC$ .
4. Prove that the centre of a circle touching two intersecting lines lies on the angle bisector of the lines.

5. In Fig. 9.13, AB and CD are common tangents to two circles of unequal radii. Prove that  $AB = CD$ .

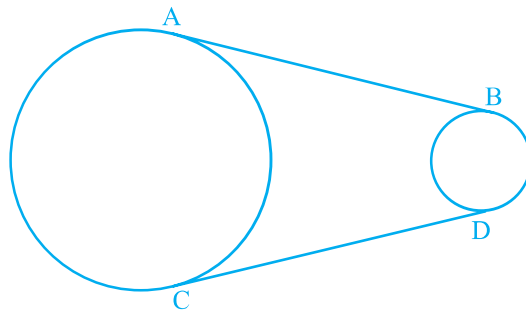

Fig. 9.13

6. In Question 5 above, if radii of the two circles are equal, prove that  $AB = CD$ .

7. In Fig. 9.14, common tangents AB and CD to two circles intersect at E. Prove that  $AB = CD$ .

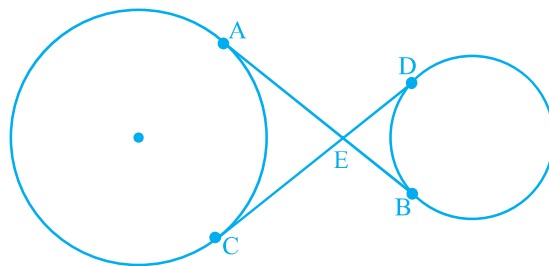

Fig. 9.14

8. A chord PQ of a circle is parallel to the tangent drawn at a point R of the circle. Prove that R bisects the arc PRQ.

9. Prove that the tangents drawn at the ends of a chord of a circle make equal angles with the chord.
10. Prove that a diameter AB of a circle bisects all those chords which are parallel to the tangent at the point A.

### (E) Long Answer Questions

**Sample Question 1 :** In Fig. 9.15, from an external point P, a tangent PT and a line segment PAB is drawn to a circle with centre O. ON is perpendicular on the chord AB. Prove that :

- (i)  $PA \cdot PB = PN^2 - AN^2$
- (ii)  $PN^2 - AN^2 = OP^2 - OT^2$
- (iii)  $PA \cdot PB = PT^2$

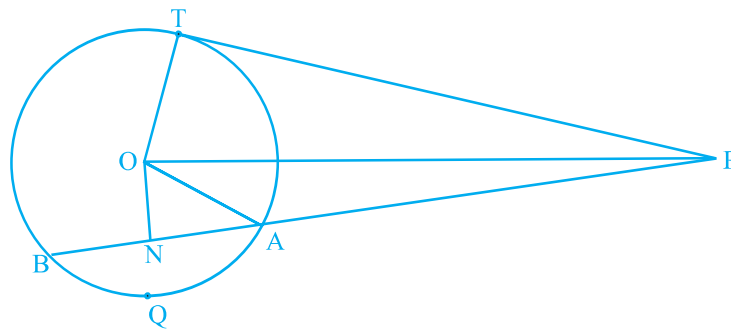

Fig. 9.15

**Solution :**

- (i)  $PA \cdot PB = (PN - AN)(PN + AN)$   
 $= (PN - AN)(PN + AN)$  (As  $AN = BN$ )  
 $= PN^2 - AN^2$
- (ii)  $PN^2 - AN^2 = (OP^2 - ON^2) - AN^2$  (As  $ON \perp PN$ )  
 $= OP^2 - (ON^2 + AN^2)$   
 $= OP^2 - OA^2$  (As  $ON \perp AN$ )  
 $= OP^2 - OT^2$  (As  $OA = OT$ )



(iii) From (i) and (ii)

$$PA \cdot PB = OP^2 - OT^2$$

$$= PT^2$$

(As  $\angle OTP = 90^\circ$ )

**Sample Question 2 :** If a circle touches the side BC of a triangle ABC at P and extended sides AB and AC at Q and R, respectively, prove that  $AQ = \frac{1}{2}(BC + CA + AB)$

**Solution :** See Fig. 9.16.

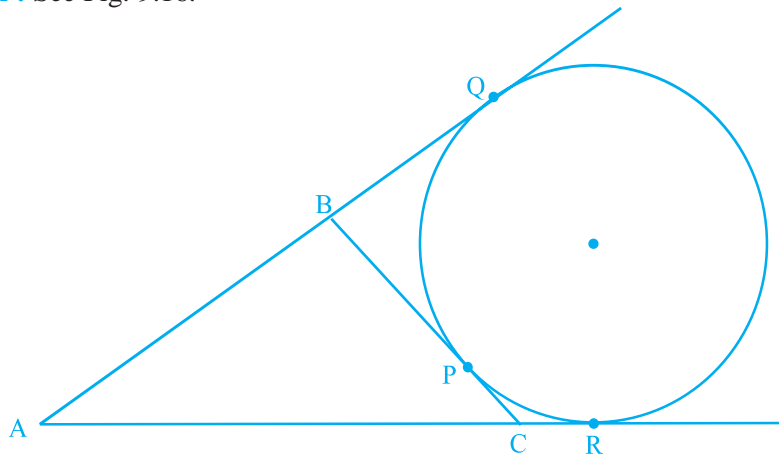

Fig. 9.16

By Theorem 10.2 of the textbook,

$$BQ = BP$$

$$CP = CR, \text{ and}$$

$$AQ = AR$$

Now,

$$2AQ = AQ + AR$$

$$= (AB + BQ) + (AC + CR)$$

$$= AB + BP + AC + CP$$

$$= (BP + CP) + AC + AB$$

$$= BC + CA + AB$$

i.e.,  $AQ = \frac{1}{2}(BC + CA + AB).$

### EXERCISE 9.4

1. If a hexagon  $ABCDEF$  circumscribe a circle, prove that  $AB + CD + EF = BC + DE + FA$ .
2. Let  $s$  denote the semi-perimeter of a triangle  $ABC$  in which  $BC = a$ ,  $CA = b$ ,  $AB = c$ . If a circle touches the sides  $BC$ ,  $CA$ ,  $AB$  at  $D$ ,  $E$ ,  $F$ , respectively, prove that  $BD = s - b$ .
3. From an external point  $P$ , two tangents,  $PA$  and  $PB$  are drawn to a circle with centre  $O$ . At one point  $E$  on the circle tangent is drawn which intersects  $PA$  and  $PB$  at  $C$  and  $D$ , respectively. If  $PA = 10$  cm, find the the perimeter of the triangle  $PCD$ .
4. If  $AB$  is a chord of a circle with centre  $O$ ,  $AOC$  is a diameter and  $AT$  is the tangent at  $A$  as shown in Fig. 9.17. Prove that  $\angle BAT = \angle ACB$

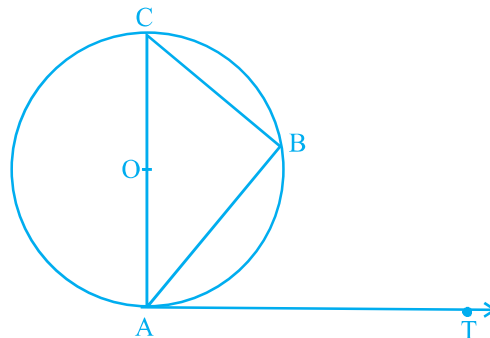

Fig. 9.17

5. Two circles with centres  $O$  and  $O'$  of radii 3 cm and 4 cm, respectively intersect at two points  $P$  and  $Q$  such that  $OP$  and  $O'P$  are tangents to the two circles. Find the length of the common chord  $PQ$ .
6. In a right triangle  $ABC$  in which  $\angle B = 90^\circ$ , a circle is drawn with  $AB$  as diameter intersecting the hypotenuse  $AC$  at  $P$ . Prove that the tangent to the circle at  $P$  bisects  $BC$ .
7. In Fig. 9.18, tangents  $PQ$  and  $PR$  are drawn to a circle such that  $\angle RPQ = 30^\circ$ . A chord  $RS$  is drawn parallel to the tangent  $PQ$ . Find the  $\angle RQS$ .

[Hint: Draw a line through Q and perpendicular to QP.]

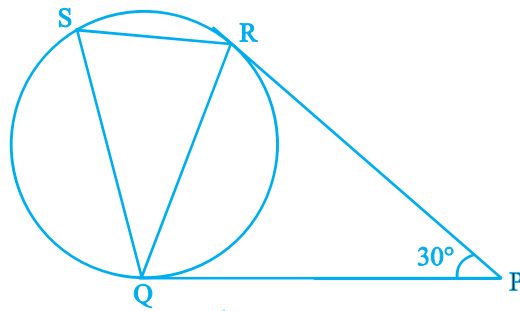

Fig. 9.18

8. AB is a diameter and AC is a chord of a circle with centre O such that  $\angle BAC = 30^\circ$ . The tangent at C intersects extended AB at a point D. Prove that  $BC = BD$ .
9. Prove that the tangent drawn at the mid-point of an arc of a circle is parallel to the chord joining the end points of the arc.
10. In Fig. 9.19, the common tangent, AB and CD to two circles with centres O and O' intersect at E. Prove that the points O, E, O' are collinear.

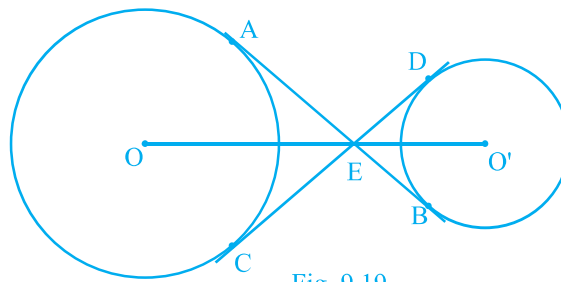

Fig. 9.19

11. In Fig. 9.20. O is the centre of a circle of radius 5 cm, T is a point such that  $OT = 13$  cm and OT intersects the circle at E. If AB is the tangent to the circle at E, find the length of AB.

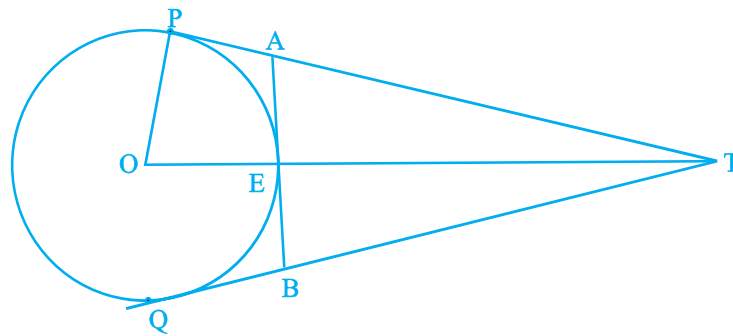

Fig. 9.20

12. The tangent at a point C of a circle and a diameter AB when extended intersect at P. If  $\angle PCA = 110^\circ$ , find  $\angle CBA$  [see Fig. 9.21].

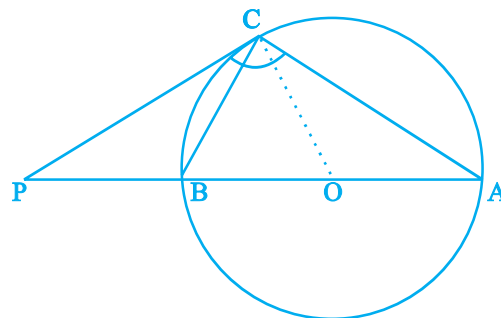

Fig. 9.21

[**Hint:** Join C with centre O.]

13. If an isosceles triangle ABC, in which  $AB = AC = 6$  cm, is inscribed in a circle of radius 9 cm, find the area of the triangle.
14. A is a point at a distance 13 cm from the centre O of a circle of radius 5 cm. AP and AQ are the tangents to the circle at P and Q. If a tangent BC is drawn at a point R lying on the minor arc PQ to intersect AP at B and AQ at C, find the perimeter of the  $\triangle ABC$ .

