

## CHAPTER 13

# ORGANISMS AND POPULATIONS

### MULTIPLE-CHOICE QUESTIONS

1. Autecology is the:
  - a. Relation of a population to its environment
  - b. Relation of an individual to its environment
  - c. Relation of a community to its environment
  - d. Relation of a biome to its environment
  
2. Ecotone is:
  - a. A polluted area
  - b. The bottom of a lake
  - c. A zone of transition between two communities
  - d. A zone of developing community
  
3. Biosphere is:
  - a. a component in the ecosystem
  - b. composed of the plants present in the soil
  - c. life in the outer space
  - d. composed of all living organisms present on earth which interact with the physical environment
  
4. Ecological niche is:
  - a. the surface area of the ocean
  - b. an ecologically adapted zone
  - c. the physical position and functional role of a species within the community
  - d. formed of all plants and animals living at the bottom of a lake

5. According to Allen's Rule, the mammals from colder climates have:
  - a. shorter ears and longer limbs
  - b. longer ears and shorter limbs
  - c. longer ears and longer limbs
  - d. shorter ears and shorter limbs
  
6. Salt concentration (Salinity) of the sea measured in parts per thousand is:
  - a. 10 - 15
  - b. 30 - 70
  - c. 0 - 5
  - d. 30 - 35
  
7. Formation of tropical forests needs mean annual temperature and mean annual precipitation as:
  - a. 18 - 25°C and 150 - 400 cm
  - b. 5 - 15°C and 50 - 100 cm
  - c. 30 - 50°C and 100 - 150 cm
  - d. 5 - 15°C and 100 - 200 cm
  
8. Which of the following forest plants controls the light conditions at the ground?
  - a. Lianas and climbers
  - b. Shrubs
  - c. Tall trees
  - d. Herbs
  
9. What will happen to a well growing herbaceous plant in the forest if it is transplanted outside the forest in a park?
  - a. It will grow normally
  - b. It will grow well because it is planted in the same locality
  - c. It may not survive because of change in its micro climate
  - d. It grows very well because the plant gets more sunlight
  
10. If a population of 50 *Paramecium* present in a pool increases to 150 after an hour, what would be the growth rate of population?
  - a. 50 per hour
  - b. 200 per hour
  - c. 5 per hour
  - d. 100 per hour

11. What would be the per cent growth or birth rate per individual per hour for the same population mentioned in the previous question (Question 10)?
  - a. 100
  - b. 200
  - c. 50
  - d. 150
12. A population has more young individuals compared to the older individuals. What would be the status of the population after some years?
  - a. It will decline
  - b. It will stabilise
  - c. It will increase
  - d. It will first decline and then stabilise
13. What parameters are used for tiger census in our country's national parks and sanctuaries?
  - a. Pug marks only
  - b. Pug marks and faecal pellets
  - c. Faecal pellets only
  - d. Actual head counts
14. Which of the following would necessarily decrease the density of a population in a given habitat?
  - a. Natality > mortality
  - b. Immigration > emigration
  - c. Mortality and emigration
  - d. Natality and immigration
15. A protozoan reproduces by binary fission. What will be the number of protozoans in its population after six generations?
  - a. 128
  - b. 24
  - c. 64
  - d. 32
16. In 2005, for each of the 14 million people present in a country, 0.028 were born and 0.008 died during the year. Using exponential equation, the number of people present in 2015 is predicted as:
  - a. 25 millions
  - b. 17 millions
  - c. 20 millions
  - d. 18 millions

17. Amensalism is an association between two species where:
  - a. one species is harmed and other is benefitted
  - b. one species is harmed and other is unaffected
  - c. one species is benefitted and other is unaffected
  - d. both the species are harmed.
  
18. Lichens are the associations of:
  - a. bacteria and fungus
  - b. algae and bacterium
  - c. fungus and algae
  - d. fungus and virus
  
19. Which of the following is a partial root parasite?
  - a. Sandal wood
  - b. Mistletoe
  - c. *Orobanche*
  - d. *Ganoderma*
  
20. Which one of the following organisms reproduces sexually only once in its life time?
  - a. Banana plant
  - b. Mango
  - c. Tomato
  - d. Eucalyptus

#### VERY SHORT ANSWER TYPE QUESTIONS

1. Species that can tolerate narrow range of temperature are called \_\_\_\_\_.
2. What are Eurythermic species?
3. Species that can tolerate wide range of salinity are called \_\_\_\_\_.
4. Define stenohaline species.
5. What is the interaction between two species called?
6. What is commensalism?
7. Name the association in which one species produces poisonous substance or a change in environmental conditions that is harmful to another species.
8. What is Mycorrhiza?

9. Emergent land plants that can tolerate the salinities of the sea are called.
10. Why do high altitude areas have brighter sunlight and lower temperatures as compared to the plains?
11. What is homeostasis?
12. Define aestivation.
13. What is diapause and its significance?
14. What would be the growth rate pattern, when the resources are unlimited?
15. What are the organisms that feed on plant sap and other plant parts called?
16. What is high altitude sickness? Write its symptoms.
17. Give a suitable example for commensalism.
18. Define ectoparasite and endoparasite and give suitable examples.
19. What is brood parasitism? Explain with the help of an example.

### SHORT ANSWER TYPE QUESTIONS

1. Why are coral reefs not found in the regions from west Bengal to Andhra Pradesh but are found in Tamil Nadu and on the east coast of India?
2. If a fresh water fish is placed in an aquarium containing sea water, will the fish be able to survive? Explain giving reasons.
3. Why do all the fresh water organisms have contractile vacuoles whereas majority of marine organisms lack them?
4. Define heliophytes and sciophytes. Name a plant from your locality that is either heliophyte or sciophyte.
5. Why do submerged plants receive weaker illumination than exposed floating plants in a lake?
6. In a sea shore, the benthic animals live in sandy, muddy and rocky substrata and accordingly developed the following adaptations.
  - a. Burrowing
  - b. Building cubes
  - c. Holdfasts / peduncle

Find the suitable substratum against each adaptation.

7. Categorise the following plants into hydrophytes, halophytes, mesophytes and xerophytes. Give reasons for your answers.
- Salvinia*
  - Opuntia*
  - Rhizophora*
  - Mangifera*

8. In a pond, we see plants which are free-floating; rooted-submerged; rooted emergent; rooted with floating leaves. Write the type of plants against each of them.

Plant Name	Type
a. <i>Hydrilla</i>	_____
b. <i>Typha</i>	_____
c. <i>Nymphaea</i>	_____
d. <i>Lemna</i>	_____
e. <i>Vallisnaria</i>	_____

9. The density of a population in a habitat per unit area is measured in different units. Write the unit of measurement against the following:
- Bacteria \_\_\_\_\_
  - Banyan \_\_\_\_\_
  - Deer \_\_\_\_\_
  - Fish \_\_\_\_\_

10.

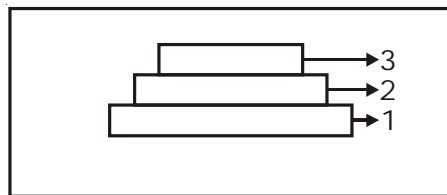

- Label the three tiers 1, 2, 3 given in the above age pyramid.
  - What type of population growth is represented by the above age pyramid?
11. In an association of two animal species, one is a termite which feeds on wood and the other is a protozoan *Trichonympha* present in the gut of the termite. What type of association they establish?
12. Lianas are vascular plants rooted in the ground and maintain erectness of their stem by making use of other trees for support. They do not maintain direct relation with those trees. Discuss the type of association the lianas have with the trees.

13. Give the scientific names of any two microorganisms inhabiting the human intestine.
14. What is a tree line?
15. Define 'zero population growth rate'. Draw a age pyramid for the same.
16. List any four characters that are employed in human population census.
17. Give one example for each of the following types.
- Migratory animal
  - Camouflaged animal
  - Predator animal
  - Biological control agent
  - Phytophagous animal
  - Chemical defense agent

18. Fill in the blanks

Species A	Species B	Type of Interaction	Example
+	-	_____	_____
+	+	_____	_____
+	_____	Commensalism	_____

19. Observe the set of 4 figures A, B, C and D and, answer the following questions
- Which one of the figures shows mutualism?
  - What kind of association is shown in D?
  - Name the organisms and the association in C.
  - What role is the insect performing in B?



Fig. (A)

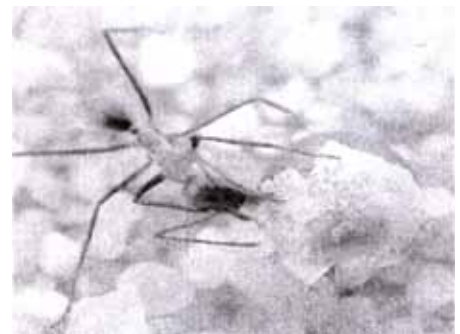

Fig. (B)



Fig. (C)



Fig. (D)

**LONG ANSWER QUESTIONS**

1. Comment on the following figures: 1, 2 and 3:  
 A, B, C, D, G, P, Q, R, S are species

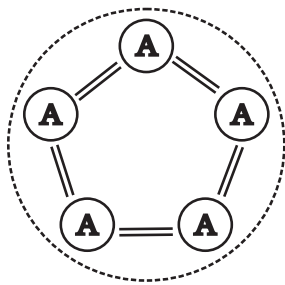

Fig. 1

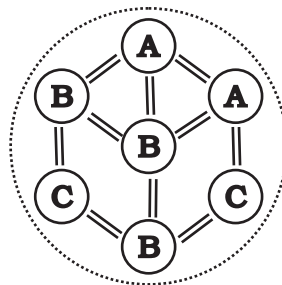

Fig. 2

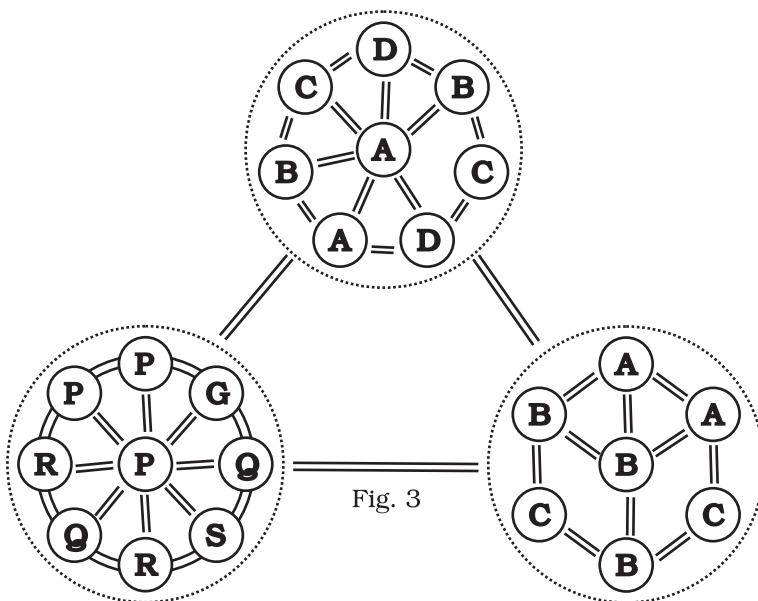
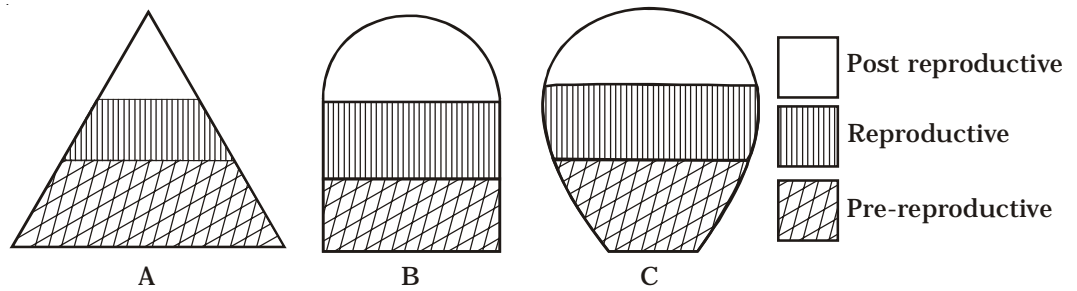

Fig. 3



- An individual and a population has certain characteristics. Name these attributes with definitions.
- The following diagrams are the age pyramids of different populations. Comment on the status of these populations.



- Comment on the growth curve given below.

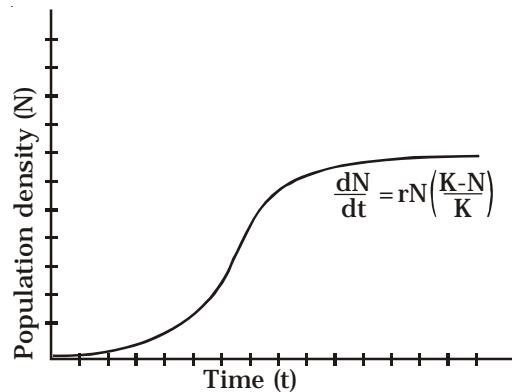

- A population of *Paramecium caudatum* was grown in a culture medium. After 5 days the culture medium became overcrowded with *Paramecium* and had depleted nutrients. What will happen to the population and what type of growth curve will the population attain? Draw the growth curve.
- Discuss the various types of positive interactions between species.
- In an aquarium two herbivorous species of fish are living together and feeding on phytoplanktons. As per the Gause's Principle, one of the species is to be eliminated in due course of time, but both are surviving well in the aquarium. Give possible reasons.
- While living in and on the host species, the animal parasite has evolved certain adaptations. Describe these adaptations with examples.

9. Do you agree that regional and local variations exist within each biome? Substantiate your answer with suitable example.
10. Which element is responsible for causing soil salinity? At what concentration does the soil become saline?
11. Does light factor affect the distribution of organisms? Write a brief note giving suitable examples of either plants or animals.
12. Give one example for each of the following:
- |  |       |
|--|-------|
| i. Eurythermal plant species                   | _____ |
| ii. A hot water spring organism                | _____ |
| iii. An organism seen in deep ocean trenches   | _____ |
| iv. An organism seen in compost pit            | _____ |
| v. A parasitic angiosperm                      | _____ |
| vi. A stenothermal plant species               | _____ |
| vii. Soil organism                             | _____ |
| viii. A benthic animal                         | _____ |
| ix. Antifreeze compound seen in antarctic fish | _____ |
| x. An organism which can conform               | _____ |